

Datasheet MBZ-EKO 406 F 1200

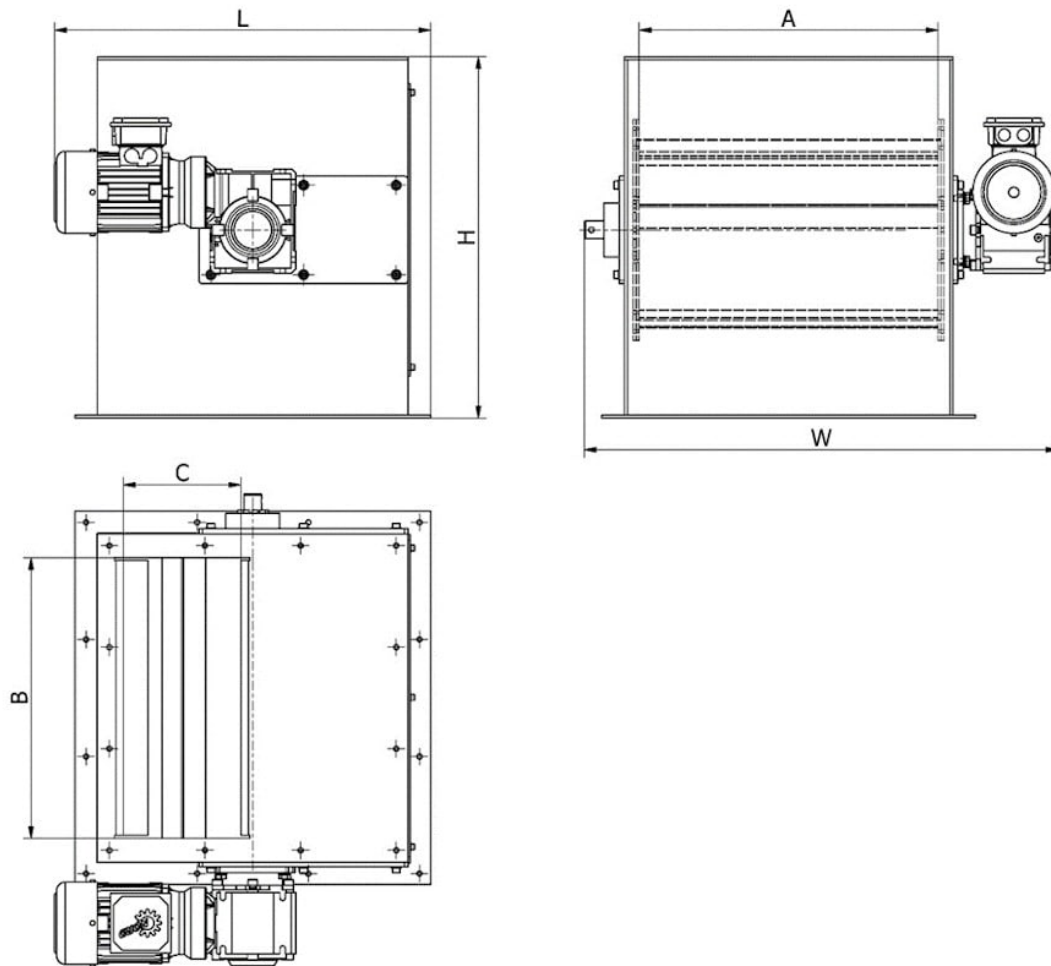

Model	Flow capacity (m ³ /h)	Weight (kg)	Dimensions (mm)					
			A	B	C	W	L	H
MBZ-EKO 406 F 400	45	625	400	370	250	730	780	805
MBZ-EKO 406 F 500	55	325	500	470	250	830	780	805
MBZ-EKO 406 F 600	65	375	600	570	250	930	780	805
MBZ-EKO 406 F 700	75	425	700	670	250	1030	780	805
MBZ-EKO 406 F 800	90	475	800	770	250	1130	780	805
MBZ-EKO 406 F 900	120	575	900	870	250	1230	780	805
MBZ-EKO 406 F 1000	140	625	1000	970	250	1330	780	805
MBZ-EKO 406 F 1100	160	675	1100	1070	250	1430	780	805
MBZ-EKO 406 F 1200	180	725	1200	1170	250	1530	780	805
MBZ-EKO 406 F 1300	200	775	1300	1270	250	1630	780	805

Parameter name	Value
Description:	Magnetic drum in a housing
Separator placement:	under the conveyor belt, under the feeding hopper, inside of a pipeline
Application (= the material that the application of this separator is suitable for):	bulk material
Material flow direction):	vertical, horizontal
Recommended for the belt of max. width (across the conveyor belt) (mm):	1200
Maximum effective reach of the magnetic field (mm):	30
Built-in standard magnet type:	ferrite magnet
Max. magnetic induction (G) on the surface of tube (+/- 10 %):	1450
Magnetic flux (G) on the magnetic core (+/- 10 %):	2800
Maximum capacity. The mentioned capacities are informative and non binding (m3/h):	180
Weight of the separator (kg):	725
Connecting dimension, inlet and outlet diameter of the separator (mm):	1200
Standard connection of the separator:	square flange, suspension holes
Separator is suitable also even for the materials of poor bulk properties:	yes
Minimum size of the particles that can be captured by the separator (mm):	1.5
Maximum size of the particles that can be captured by the separator (mm):	50
Max. operating temperature (°C):	100
Min. surrounding ambient temperature (°C):	-25
Max. surrounding ambient temperature (°C):	45
Material of the sealing:	silicone + NBR
Separator is suitable for vacuum or pressure conveying lines:	no
Separator is suitable for materials transported by:	conveyor belt, gravity, pipeline
Separator is able to capture paramagnetic particles:	no
Separator is suitable for abrasive materials (1 = strongly abrasive, 2 = slightly abrasive, 3 = non-abrasive):	2

Separator is suitable for materials that tend to solidify (the materials must be heated):	no
Separation of non-ferrous metals:	no
Standard requirements for the installation:	electricity supply corresponding with the motor parameters
Cleaning of the separator:	fully automatic cleaning, it is not necessary to interrupt the material flow during the cleaning
Material of the separator body (that is in contact with the material):	DIN 1.4301
ATEX (on request):	zone 21, 22
Outer surface treatment of the separator:	sandblasted
Inner surface treatment of the separator:	clean steel (no surface treatment) + sandblasted
Magnetic system:	magnetic drum
Motor brand:	Nord
Main motor input (kW):	1.1
Definition of the main motor electrical connection:	400 V, AC, 50 Hz, , PE-N, TN-C-S, circuite breaker 3F/32A
Available motor variants (the variant mentioned as the first is the standard one):	electric motor
Degree of motor protection (against dust and water):	IP55
Rotational speed of the engine (rev/min):	28
Bearings:	SNR
Availbe lubrication methods for the bearings:	mánual
Standard electrical equipment of the separator:	no external electric cable, no frequency convertor, no electric switchboard, wiring is terminated at the motor screw terminal
Options of the extended anti-abrasion protection:	chemical nickel coating, plastic coating, rubberizing, ceramic lining
Other standard parameters:	
Other additionally paid options:	device for manual setting of the position of the magnetic core, dust extraction opening, inner polishing
Max. operation time (hours/day):	24
Max. production time for a standard version (if not available in stock) (weeks):	8
Standard packing:	pallet + stretch wrap
Other packing modes (surcharged options):	wooden box, maritime packing according to clients needs
Warranty (months):	60

The guarantee does not apply to:

driveline, bearings, magnetic drum surface, wear parts (rubber dampers, seals)

This product can be delivered also in different dimensions, in the versions with a higher temperature resistance, different magnets etc. upon a special request. The mentioned capacity is only approximative and depends on the type of the cleaned material. The maximum effective reach of the magnetic field is measured from the surface of the magnetic drum. Maximum material limit (MMC): 50 x 50 x 50 mm