

Datasheet MBZ-EKO 506 N 1000

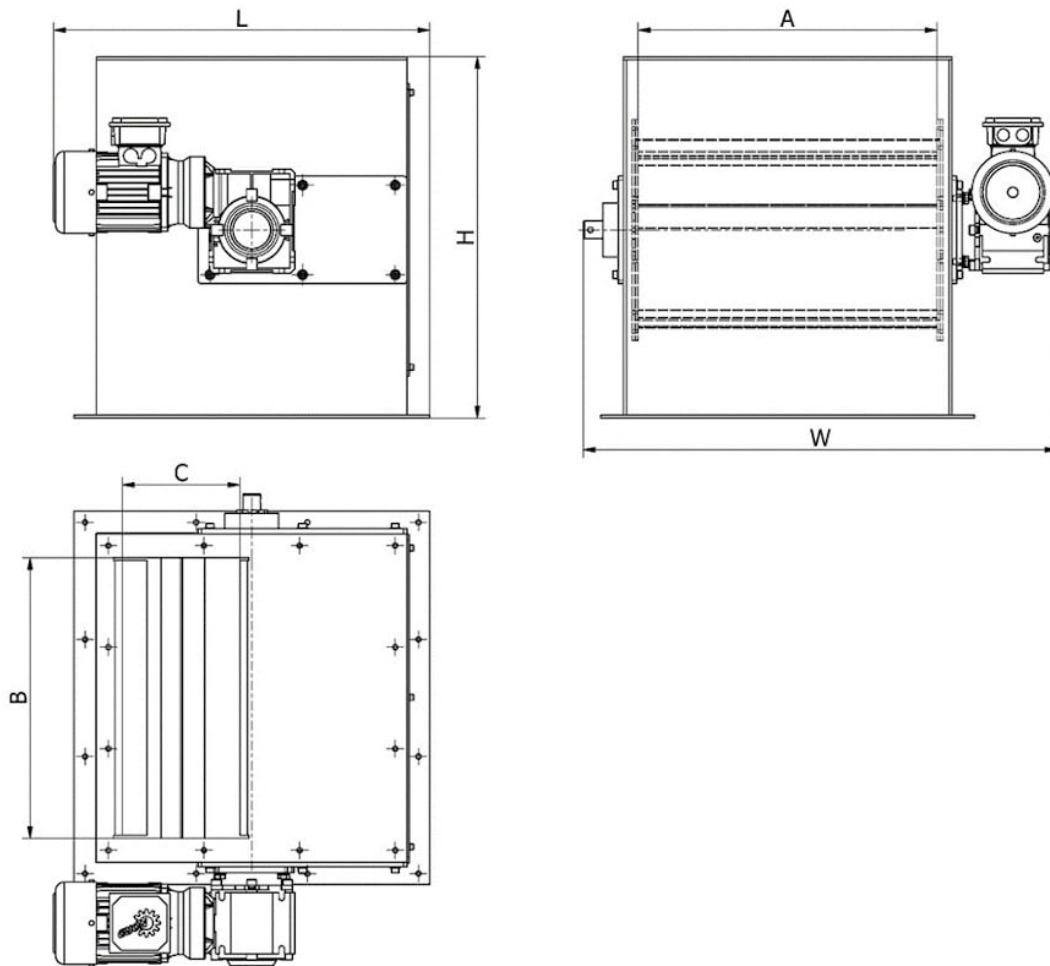

Model	Flow capacity (m ³ /h)	Weight (kg)	Dimensions (mm)					
			A	B	C	W	L	H
MBZ-EKO 506 N 500	70	800	500	470	300	860	930	1005
MBZ-EKO 506 N 600	85	500	600	570	300	960	930	1005
MBZ-EKO 506 N 700	105	550	700	670	300	1060	930	1005
MBZ-EKO 506 N 800	125	600	800	770	300	1160	930	1005
MBZ-EKO 506 N 900	145	650	900	870	300	1260	930	1005
MBZ-EKO 506 N 1000	180	700	1000	970	300	1360	930	1005
MBZ-EKO 506 N 1100	215	750	1100	1070	300	1460	930	1005
MBZ-EKO 506 N 1200	250	800	1200	1170	300	1560	930	1005
MBZ-EKO 506 N 1300	285	850	1300	1270	300	1660	930	1005

Parameter name	Value
Description:	Magnetic drum in a housing
Separator placement:	under the conveyor belt, under the feeding hopper, inside of a pipeline
Application (= the material that the application of this separator is suitable for):	bulk material
Material flow direction):	vertical, horizontal
Recommended for the belt of max. width (across the conveyor belt) (mm):	1000
Maximum effective reach of the magnetic field (mm):	30
Built-in standard magnet type:	neodymium magnet N35
Max. magnetic induction (G) on the surface of tube (+/- 10 %):	3300
Magnetic flux (G) on the magnetic core (+/- 10 %):	6000
Maximum capacity. The mentioned capacities are informative and non binding (m3/h):	180
Weight of the separator (kg):	700
Connecting dimension, inlet and outlet diameter of the separator (mm):	1000
Standard connection of the separator:	square flange, suspension holes
Separator is suitable also even for the materials of poor bulk properties:	yes
Minimum size of the particles that can be captured by the separator (mm):	0.1
Maximum size of the particles that can be captured by the separator (mm):	50
Max. operating temperature (°C):	80
Min. surrounding ambient temperature (°C):	-25
Max. surrounding ambient temperature (°C):	45
Material of the sealing:	silicone + NBR
Separator is suitable for vacuum or pressure conveying lines:	no
Separator is suitable for materials transported by:	conveyor belt, gravity, pipeline
Separator is able to capture paramagnetic particles:	yes
Separator is suitable for abrasive materials (1 = strongly abrasive, 2 = slightly abrasive, 3 = non-abrasive):	2

Separator is suitable for materials that tend to solidify (the materials must be heated):	no
Separation of non-ferrous metals:	no
Standard requirements for the installation:	electricity supply corresponding with the motor parameters
Cleaning of the separator:	fully automatic cleaning, it is not necessary to interrupt the material flow during the cleaning
Material of the separator body (that is in contact with the material):	DIN 1.4301
ATEX (on request):	zone 21, 22
Outer surface treatment of the separator:	sandblasted
Inner surface treatment of the separator:	clean steel (no surface treatment) + sandblasted
Magnetic system:	magnetic drum
Motor brand:	Nord
Main motor input (kW):	1.1
Definition of the main motor electrical connection:	400 V, AC, 50 Hz, , PE-N, TN-C-S,circuite breaker 3F/32A
Available motor variants (the variant mentioned as the first is the standard one):	electric motor
Degree of motor protection (against dust and water):	IP55
Rotational speed of the engine (rev/min):	28
Bearings:	SNR
Availble lubrication methods for the bearings:	mna
Standard electrical equipment of the separator:	no external electric cable, no frequency convertor, no electric switchboard, wiring is terminated at the motor screw terminal
Options of the extended anti-abrasion protection:	chemical nickel coating, plastic coatid rubberizing,ceramic tlining
Other standard parameters:	
Other additionally paid options:	device for manual setting of the position of the magnetic core, dust extraction opening, inner polishing
Max. operation time (hours/day):	24
Max. production time for a standard version (if not available in stock) (weeks):	8
Standard packing:	pallet + stretch wrap
Other packing modes (surcharged options):	wooden box, maritime packing according to clients needs
Warranty (months):	60

The guarantee does not apply to:

driveline, bearings, magnetic drum surface, wear parts (rubber dampers, seals)

This product can be delivered also in different dimensions, in the versions with a higher temperature resistance, different magnets etc. upon a special request. The mentioned capacity is only approximative and depends on the type of the cleaned material. The maximum effective reach of the magnetic field is measured from the surface of the magnetic drum. Maximum material limit (MMC): 50 x 50 x 50 mm