

# Datasheet MSP-SC 250 N ORCA

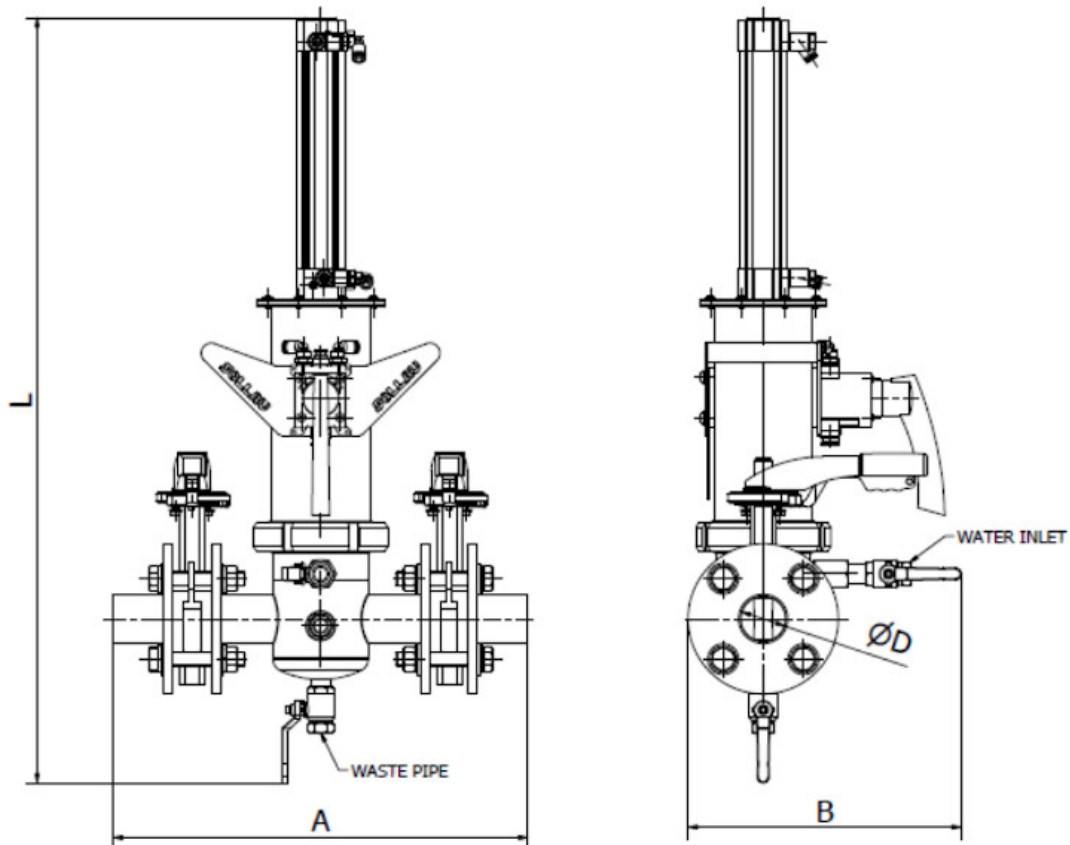

Model	Weight (kg)	Dimensions (mm)				Pipeline diameter (inches)		Number of tubes
		ØD	A	B	L	Water supply (3 bars)	Waste	
MSP-SC 50 N ORCA	42	50	460	300	850	G1/2"	G1/2"	3 x 32 mm
MSP-SC 100 N ORCA	70	100	580	350	1050	G1/2"	G1/2"	5 x 32 mm
MSP-SC 150 N ORCA	140	150	950	500	1400	2xG1/2"	G1"	7 x 32 mm
MSP-SC 200 N ORCA	170	200	1050	600	1600	2xG1/2"	G1"	10 x 32 mm
MSP-SC 250 N ORCA	230	250	1350	680	1800	3xG1/2"	G1"	15 x 32 mm

Parameter name	Value
Description:	Pipeline magnetic separator (with semi-automatic cleaning)

Application (= the material that the application of this separator is suitable for):	liquid material, bulk material
Material flow direction):	vertical, horizontal
Built-in standard magnet type:	neodymium magnet N35
Max. magnetic induction (G) on the surface of tube (+/- 10 %):	10 700 (optional variant with magnets N52: 12 200)
Magnetic flux (G) on the magnetic core (+/- 10 %):	17 000 (optional variant with magnets N52: 18 700)
Maximum capacity. The mentioned capacities are informative and non binding (m <sup>3</sup> /h):	415
Weight of the separator (kg):	115
Connecting dimension, inlet and outlet diameter of the separator (mm):	DN250
Standard connection of the separator:	flange EN 1092-1
Minimum size of the particles that can be captured by the separator (mm):	0.03
Max. operating temperature (°C):	80
Min. surrounding ambient temperature (°C):	-25
Max. surrounding ambient temperature (°C):	45
Operating pressure:	max. 8 bar
Material of the sealing:	silicone
Separator is suitable for vacuum or pressure conveying lines:	yes
Separator is able to capture paramagnetic particles:	yes
Separator is suitable for abrasive materials (1 = strongly abrasive, 2 = slightly abrasive, 3 = non-abrasive):	3
Standard requirements for the installation:	compressed air supply (of 6 - 8 bar), water supply (3 bar)
Cleaning of the separator:	semi-automatic cleaning, it is necessary to interrupt the material flow during the cleaning
Diameter of the outer (protective) tube of the magnetic rod (mm):	32
Diameter of magnetic rod (mm):	29
Number of magnetic tubes:	13
Material of the separator body (that is in contact with the material):	AISI 304 (DIN 1.4301)
ATEX (on request):	zone 20, 21, 22
Outer surface treatment of the separator:	sandblasted

Inner surface treatment of the separator:	sandblasted + polished tube
Other standard parameters:	manually operated inlets and outlets, rinsing system, pneumatic components FESTO
Other additionally paid options:	magnets N52, magnets with higher temperature resistance, pressure resistance above 8 bars, polished version, sight glass
Max. operation time (hours/day):	24
Max. production time for a standard version (if not available in stock) (weeks):	6-8
Standard packing:	wooden box
Other packing modes (surcharged options):	pallet, maritime packing according to clients needs
Warranty (months):	12

The mentioned capacity is only approximative and depends on the type of the cleaned material. This product can be delivered also in different dimensions, in the versions with a higher temperature resistance, different magnets etc. upon a special request. • Standard version (without an official pressure certificate): resistant up to 6 bars • Above standard version (with an official pressure certificate): resistant above 6 bars • Additional option: official pressure certificate