

Datasheet MT 250 F

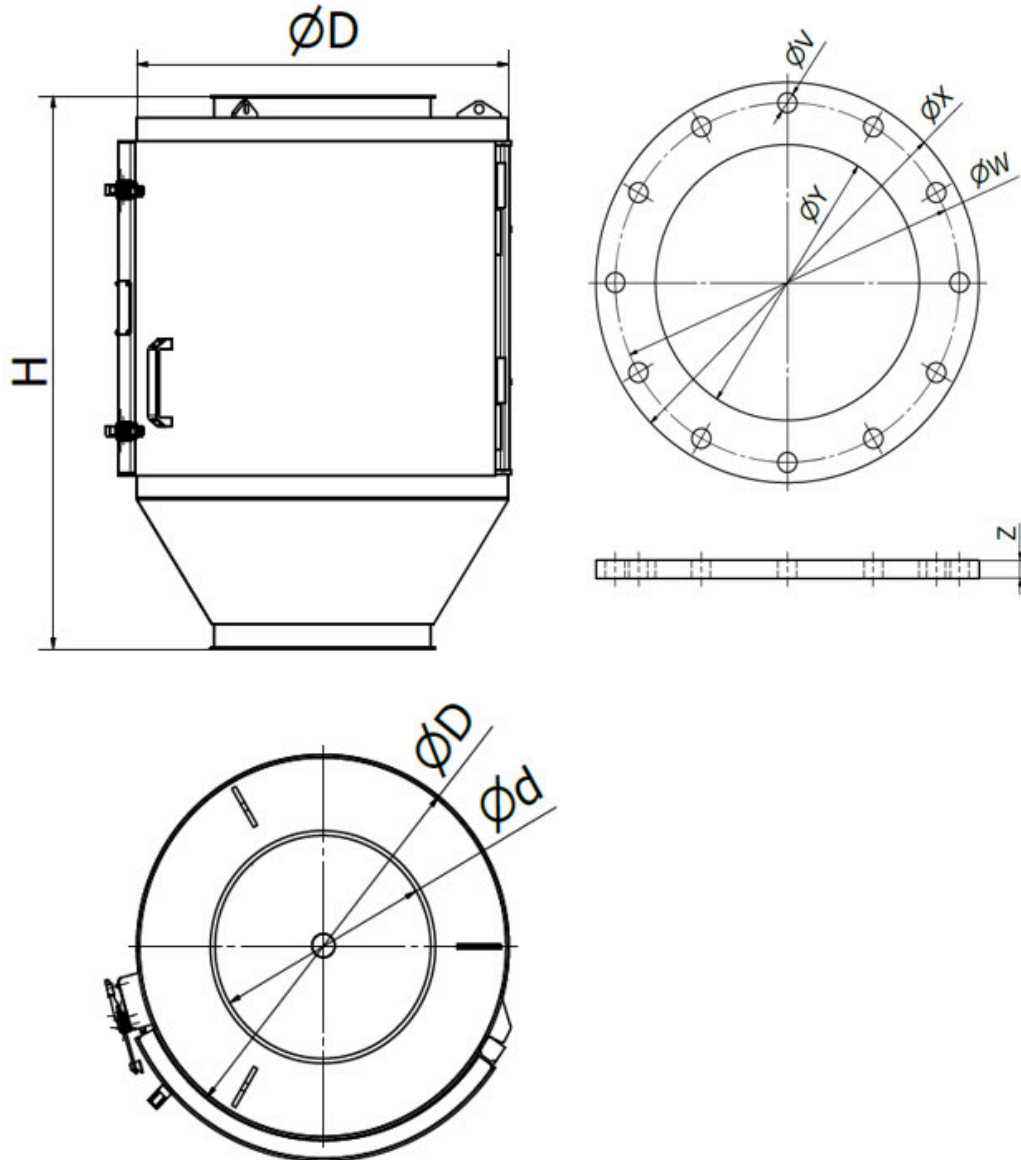

Model	Max. flow capacity (m ³ /h)	Weight (kg)	Dimensions (mm)		
			$\varnothing d$	$\varnothing D$	H
MT 100 F	10	158	99	460	850
MT 150 F	25	204	149	510	900
MT 200 F	60	259	199	560	950
MT 250 F	90	302	249	610	1000
MT 300 F	130	355	299	660	1050
MT 350 F	165	408	349	710	1100

MT 400 F	230	456	398	760	1150
MT 500 F	360	550	498	860	1250

Dimensions of standard flanges

Flange type	Number of holes	Dimensions (mm)				
		øV	øW	øX	øY	Z
DN 100	8	18	180	220	100	5
DN 150	8	22	240	285	150	5
DN 200	8	22	295	340	200	8
DN 250	12	22	350	395	250	8
DN 300	12	22	400	445	300	10
DN 350	16	22	460	505	350	12
DN 400	16	26	515	565	400	15
DN 500	20	26	620	670	500	15

Parameter name	Value
Description:	In-line magnetic separator
Separator placement:	inside of a pipeline
Application (= the material that the application of this separator is suitable for):	bulk material
Material flow direction):	vertical
Built-in standard magnet type:	ferrite magnet
Max. magnetic induction (G) on the surface of tube (+/- 10 %):	1300
Maximum capacity. The mentioned capacities are informative and non binding (m ³ /h):	90
Weight of the separator (kg):	302
Connecting dimension, inlet and outlet diameter of the separator (mm):	249
Standard connection of the separator:	standard flange, JACOB flange
Separator is suitable also even for the materials of poor bulk properties:	yes
Minimum size of the particles that can be captured by the separator (mm):	1.5
Maximum size of the particles that can be captured by the separator (mm):	30
Max. operating temperature (°C):	100
Min. surrounding ambient temperature (°C):	-25

Max. surrounding ambient temperature (°C):	45
Material of the sealing:	microporous rubber
Separator is suitable for vacuum or pressure conveying lines:	up to 1 bar
Separator is suitable for materials transported by:	pipeline
Separator is able to capture paramagnetic particles:	no
Separator is suitable for abrasive materials (1 = strongly abrasive, 2 = slightly abrasive, 3 = non-abrasive):	2
Separator is suitable for materials that tend to solidify (the materials must be heated):	no
Separation of non-ferrous metals:	no
Cleaning of the separator:	manual cleaning (without easy cleaning system), a need of interrupting the material flow
Material of the separator body (that is in contact with the material):	DIN 1.4301
ATEX (on request):	zone 21, 22
Outer surface treatment of the separator:	sandblastedí
Inner surface treatment of the separator:	sandblasted
Magnetic system:	magnetic tube
Options of the extended anti-abrasion protection:	chemical nickel coating, plastic coating, rubberizing, ceramic lining
Other additionally paid options:	inner polishing
Max. operation time (hours/day):	24
Max. production time for a standard version (if not available in stock) (weeks):	8
Standard packing:	stretch wrap + cardboard box
Other packing modes (surcharged options):	wooden box, pallet, maritime packing according to clients needs
Warranty (months):	12

The mentioned capacity is only approximative and depends on the type of the cleaned material. This product can be delivered also in other dimensions, in versions with a higher temperature resistance and other kind of magnets etc. upon a special request.