

Datasheet MV-R 1500 N

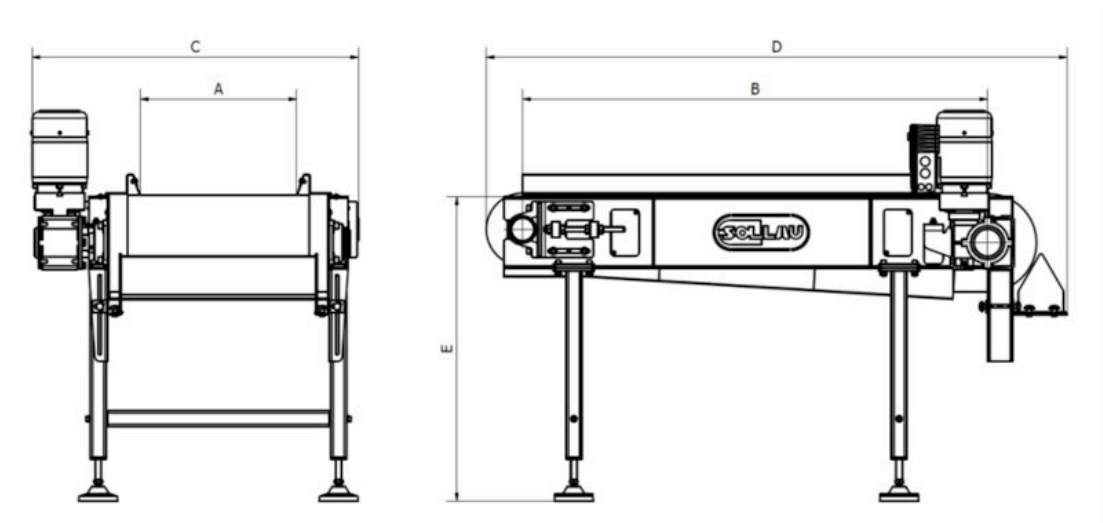

Model	Weight (kg)	Dimensions (mm)					Magnetic roller diameter (mm)
		A	B	C	D	E	
MV-R 500 N	500	500	1500	1055	1850	980	300
MV-R 1000 N	900	1000	2000	1555	2350	980	300
MV-R 1500 N	1300	1500	2500	2055	2850	980	300

Parameter name	Value
Description:	Separator for stainless steel
Separator placement:	connection to conveyor belt system
Application (= the material that the application of this separator is suitable for):	bulk material
Material flow direction):	vertical, horizontal
Recommended for the belt of max. width (across the conveyor belt) (mm):	1500
Maximum effective reach of the magnetic field (mm):	10
Built-in standard magnet type:	neodymium magnet
Max. magnetic induction (G) on the surface of tube (+/- 10 %):	11000
Weight of the separator (kg):	1300
Connecting dimension, inlet and outlet diameter of the separator (mm):	1500

Separator is suitable also even for the materials of poor bulk properties:	yes
Minimum size of the particles that can be captured by the separator (mm):	0.03
Maximum size of the particles that can be captured by the separator (mm):	20
Max. operating temperature (°C):	60
Min. surrounding ambient temperature (°C):	-25
Max. surrounding ambient temperature (°C):	45
Separator is suitable for vacuum or pressure conveying lines:	no
Separator is suitable for materials transported by:	gravity, pipeline, conveyor belt
Max. speed at which that the separator can capture ferrous particles (m/s):	1.5
Separator is able to capture paramagnetic particles:	yes
Separator is suitable for abrasive materials (1 = strongly abrasive, 2 = slightly abrasive, 3 = non-abrasive):	1
Separator is suitable for materials that tend to solidify (the materials must be heated):	no
Separation of non-ferrous metals:	no
Standard requirements for the installation:	electricity supply corresponding with the motor parameters
Cleaning of the separator:	fully automatic cleaning, it is not necessary to interrupt the material flow during the cleaning
Material of the separator body (that is in contact with the material):	DIN 1.4301
ATEX (on request):	zone 21, 22
Outer surface treatment of the separator:	painted (RAL colour tone)
Inner surface treatment of the separator:	painted (RAL colour tone)
Magnetic system:	magnetic roller
Motor brand:	Nord
Definition of the main motor electrical connection:	230V, AC, 50 Hz
Available motor variants (the variant mentioned as the first is the standard one):	electric motor
Degree of motor protection (against dust and water):	IP55
Type of the separator belt:	polyuretan

Bearings:	SNR
Available lubrication methods for the bearings:	manual
Standard electrical equipment of the separator:	frequency convertor
Other standard parameters:	neodymium magnets N52, radial poles
Other additionally paid options:	kevlar conveyor belt, glass-teflon conveyor belt, antistatic conveyor belt, conveyor belt for food applications, vibrating feeder, electric switchboard
Max. operation time (hours/day):	24
Max. production time for a standard version (if not available in stock) (weeks):	8
Standard packing:	pallet + stretch wrap
Other packing modes (surcharged options):	maritime packing according to clients needs
Warranty (months):	12

This product can be delivered also in different dimensions, in the versions with a higher temperature resistance, different magnets etc. upon a special request. The magnetic roll (= pulley) of this separator the magnets is not covered with a protective stainless steel tube (i. e., the conveyor belt is in a direct contact with the magnetic cores). The recommended height of the material layer transported on the conveyor belt: 5mm (max. height of the material layer: up to 10 mm). The thickness of the standard conveyor belt: 1.3 mm. The standard belt meets FDA standard (21 CFR 177.2600), it is antistatic (as per ISO 284/21178), flame-resistant (based on ISO 340) and rupture-resistant (according to DIN 53363). The device is equipped with height-adjustable legs.